

STAINLESS STEEL WELDING NECK FLANGE

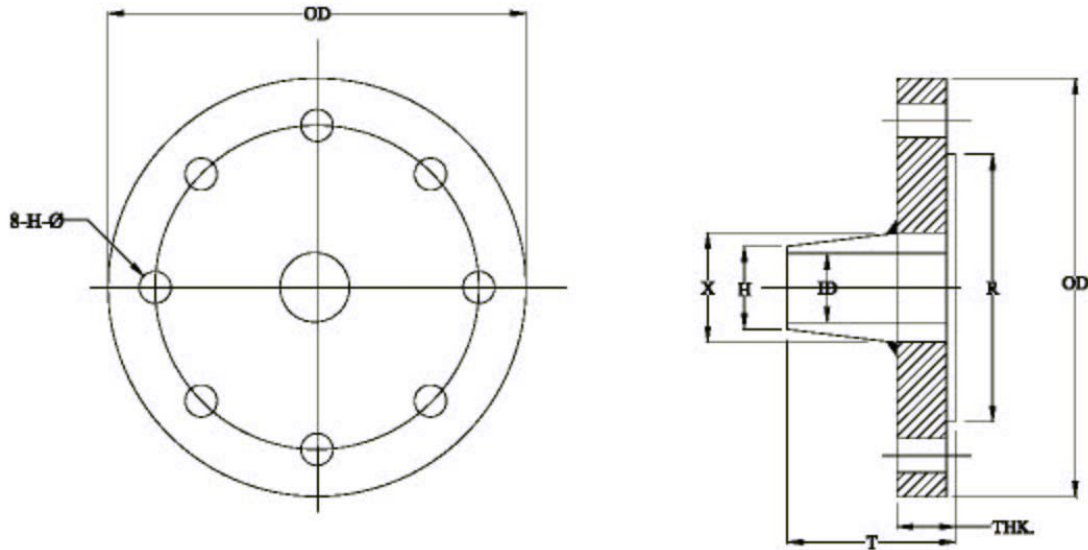

Nom. Pipe Size (inches)	OD	Lb/sq.in	THK.	R	X	No. and** Dia. of Bolt Holes	Bolt Circle Dia	T	H	ID
1/2	3.50	150	.44	1.38	1.19	4-0.62	2.38	1.88	.84	.62
3/4	3.88	150	.50	1.69	1.50	4-0.62	2.75	2.06	1.05	.82
1	4.25	150	.56	2.00	1.94	4-0.62	3.12	2.19	1.32	1.05
1 1/4	4.62	150	.62	2.50	2.31	4-0.62	3.50	2.25	1.66	1.38
1 1/2	5.00	150	.68	2.88	2.56	4-0.62	3.88	2.44	1.90	1.61
2	6.00	150	.75	3.62	3.06	4-0.75	4.75	2.50	2.38	2.07
2 1/2	7.00	150	.88	4.12	3.56	4-0.75	5.50	2.75	2.88	2.47
3	7.50	150	.94	5.00	4.25	4-0.75	6.00	2.75	3.50	3.07

Temperature Sensor Technology



1/2	3.75	0.56	300	1.38	1.50	4-0.62	2.62	2.06	0.84	0.62
3/4	4.62	0.62	300	1.69	1.88	4-0.75	3.25	2.25	1.05	0.82
1	4.88	0.69	300	2.00	2.12	4-0.75	3.50	2.44	1.32	1.05
1 1/4	5.25	0.75	300	2.50	2.50	4-0.75	3.88	2.56	1.66	1.38
1 1/2	6.12	0.81	300	2.88	2.75	4-0.88	4.50	2.69	1.90	1.61
2	6.50	0.88	300	3.62	3.31	8-0.75	5.00	2.75	2.38	2.07
2 1/2	7.50	1.00	300	4.12	3.94	8-0.88	5.88	3.00	2.88	2.47
3	8.25	1.12	300	5.00	4.62	8-0.88	6.62	3.12	3.50	3.07
1/2	3.75	0.56	400 / 600	1.38	1.50	4-0.62	2.62	2.06	0.84	0.88
3/4	4.62	0.62	400 / 600	1.69	1.88	4-0.75	3.25	2.25	1.05	1.00
1	4.88	0.69	400 / 600	2.00	2.12	4-0.75	3.50	2.44	1.32	1.06
1 1/4	5.25	0.81	400 / 600	2.50	2.50	4-0.75	3.88	2.62	1.66	1.12
1 1/2	6.12	0.88	400 / 600	2.88	2.75	4-0.88	4.50	2.75	1.90	1.25
2	6.50	1.00	400 / 600	3.62	3.31	8-0.75	5.00	2.88	2.38	1.44
2 1/2	7.50	1.12	400 / 600	4.12	3.94	8-0.88	5.88	3.12	2.88	1.62
3	8.25	1.25	400 / 600	5.00	4.62	8-0.88	6.62	3.25	3.50	1.81
1/2	4.75	0.88	900 / 1500	1.38	1.50	4-0.88	3.25	2.38	0.84	1.25
3/4	5.12	1.00	900 / 1500	1.69	1.75	4-0.88	3.50	2.75	1.05	1.38
1	5.88	1.12	900 / 1500	2.00	2.06	4-1.00	4.00	2.88	1.32	1.62
1 1/4	6.25	1.12	900 / 1500	2.50	2.50	4-1.00	4.38	2.88	1.66	1.62
1 1/2	7.00	1.25	900 / 1500	2.88	2.75	4-1.12	4.88	3.25	1.90	1.75
2	8.50	1.50	900 / 1500	3.62	4.12	8-1.00	6.50	4.00	2.38	2.25
2 1/2	9.62	1.62	900 / 1500	4.12	4.88	8-1.12	7.50	4.12	2.88	2.50
3	9.50	1.50	900 / 1500	5.00	5.00	8-1.00	7.50	4.00	3.50	2.12
1/2	5.25	1.19	2500	1.38	1.69	4-0.88	3.50	2.88	0.84	1.56
3/4	5.50	1.25	2500	1.69	2.00	4-0.88	3.75	3.12	1.05	1.69
1	6.25	1.38	2500	2.00	2.25	4-1.00	4.25	3.50	1.32	1.88
1 1/4	7.25	1.50	2500	2.50	2.88	4-1.12	5.12	3.75	1.66	2.06
1 1/2	8.00	1.75	2500	2.88	3.12	4-1.25	5.75	4.38	1.90	2.38
2	9.25	2.00	2500	3.62	3.75	8-1.12	6.75	5.00	2.38	2.75
2 1/2	10.50	2.25	2500	4.12	4.50	8-1.25	7.75	5.62	2.88	3.12
3	12.00	2.62	2500	5.00	5.25	8-1.38	9.00	6.62	3.50	3.62

Temperature Sensor Technology

TEMPSENS INSTRUMENTS (I) PVT. LTD., B 188 A, ROAD No. 5, M.I.A., UDAIPUR-313003 INDIA

PH.: +91 294 3057700, FAX : +91 294 2492447, 3057750 EMAIL : info@tempsensindia.com, Website : www.tempsensindia.com